



# Filler ALL-IN-CAN



Our flexibility for your challenges.

## Main features

- Possibilities for different cans, lids and products supported
- Industry leading changeover time
- Built to match the highest requirements for hygiene
- Different sustainable solutions available
- Drive concept with servo motors

## Applications

- Beer
- RTD's
- Soft drinks (still & sparkling)
- Wine (still & sparkling)
- Water (still & sparkling)
- Juices (including fruit pulp, up to 1x6 mm)

## Filling temperature range

- 0°- 20°C

## CO<sub>2</sub> content

- 0 – 8 gr/l

## Speed range

- 5.000 cph up to 50.000 cph

## Sizes & configurations

- Several different sizes, different configurations (w/wo rinser; different lid sizes)

## Formats

- Cans
- From 150 ml to 1.000 ml

## Closure possibilities

- Lid sizes 200, 202, 206, 209

## From small & flexible solutions ...

Configuration for Slim, Sleek, Standard and King size cans  
(10 different cans) with clean room and lid disinfection

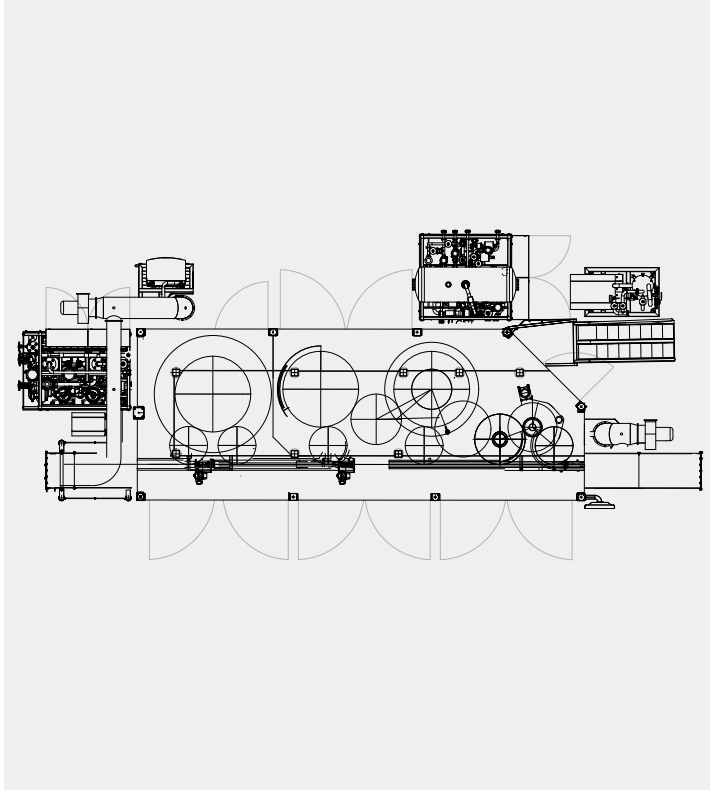

### Rinser

- Possibility of gravity rinser
- Possibility of rotary rinser with universal grippers for all can sizes
  - Space saving & flexible solution (e.g. introducing new cans in the future)
- Designed with one or two separate channels allowing the usage of different media

### Filler

- Two different filling systems available
- Double container pre-evacuation with undercover gassing & bubble breaker for low O<sub>2</sub> pick-up

### Closing systems

- Up to 12.000 cph:
  - Two different seaming applications (for different lid types, eg. slim & standard) without mechanical changeover
- Above 12.000 cph:
  - Single seaming application with a quick changeover to different lid types

## ... to bigger & customized solutions

Configuration for Slim, Sleek and Standard cans with system for Hot-fill and simple cover with HEPA filter

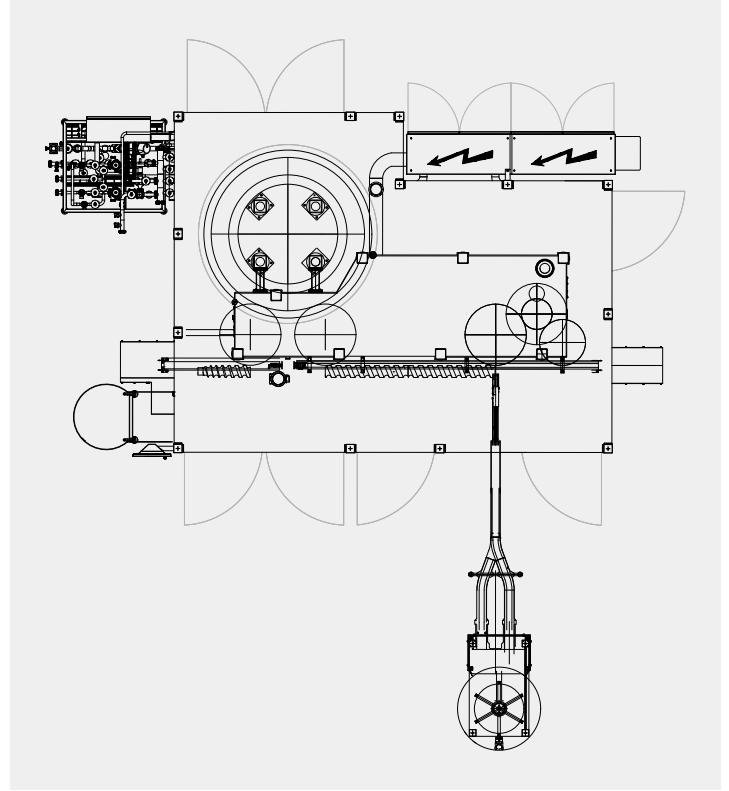

### Lid supply options

- Chute for manual lid loading
- Rotary lid supply system with lid magazine
- Automated Can End Unwrapping and Feeding System

### Options / upgrades

#### Hygiene

- External flushing system with piping and nozzles for external cleaning
- Foaming system
- Simple cover with HEPA filter or clean room
- Lid disinfection (available with VIPOLL seamers)
- Automatic CIP cap insertion

#### Sustainability

- Water re-use system
- Circulation of the disinfectant media

#### Other

- System for Hot-fill
- Different lid supply options
- Different seaming applications & combination possibilities
- Trolleys (for format parts, chucks & rolls, etc...)
- ...